

Tri-Pure HT

High Temperature HEPAs

FEATURES

- Rated up to 500 °F (260 °C)
- Quality-controlled manufacturing facility
- Microfiber media packs
- Rolled and tapered aluminum separators
- Available efficiencies from 99.97% To 99.99% @ 0.3 µm
- Available in standard and high flow models
- Gasket seal

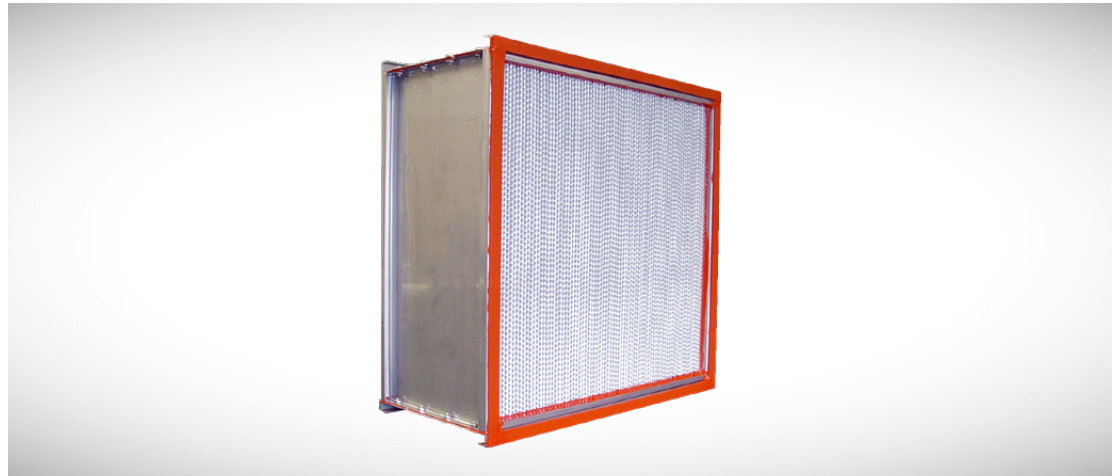

TRI-PURE HEPA HT & HEPAMAX HT SEPARATOR-STYLE FILTERS FOR CRITICAL APPLICATIONS

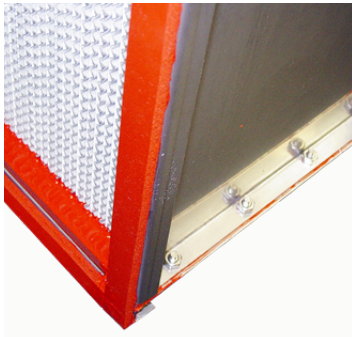

Close-up of Tri-Pure™ HEPA HT frame media pack and sealant

Tri-Dim Filter Corporation's Tri-Pure™ HEPA HT and HEPAMAX™ HT filters are designed for the challenging environments of high temperature applications where high demands are placed on HEPA filters. Tri-Pure™ high temperature filters are rated up to 500 °F (260 °C). Tri-Dim's quality controlled manufacturing facility ensures that you receive the highest quality products.

Tri-Pure™ HEPA HT and HEPAMAX™ HT filter media packs are constructed utilizing a moisture resistant, glass microfiber. The Tri-Pure™ media pack is supported by aluminum separators that are rolled and tapered and placed between each pleat to maximize performance, insure maximum air flow at minimum resistance and to protect the media pack.

HEPA filters are tested for leaks in the media pack and in the seal between the media pack and frame. Tri-Pure HT HEPA filters provides particle removal efficiencies of 99.97% and 99.99% .

Tri-Pure™ HEPA HT and HEPAMAX™ HT filters are available in a gasket seal model. The standard gasket is a ¼ x ¾" silicone sponge gasket that can handle temperatures up to 500 °F (260 °C).

The Tri-Pure™ HEPA HT and HEPAMAX™ HT filters utilize a high temperature silicone sealant. This silicone compound sealant is rated up to 500 °F (260 °C) of continual service.

Tri-Pure HT Technical Specification

TRI-PURE™ HEPA HT DRAWING

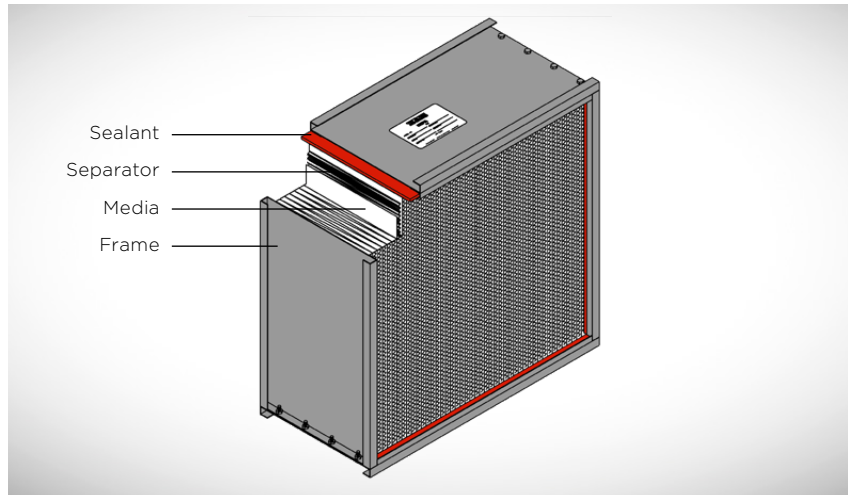

Tri-Pure™ HEPA HT and HEPAMAX™ HT filters use a stainless steel frame that is bolted together for added strength and rigidity required for demanding environments where high temperature filters are utilized.

Tri-Pure™ HEPA HT and HEPAMAX™ HT is available in standard capacity and a high flow capacity model. The HEPA HT standard capacity model is rated at 250 FPM at 1.0 "W.G. of resistance. The high flow model, with 80% more media than our standard model, is rated at 500 FPM at 1.4 "W.G. of resistance.

TECHNICAL SPECIFICATIONS

Product	TRI-PURE™ HEPA HT	TRI-PURE™ HEPAMAX HT
Recommended air flow	250 FPM (1.3 m/s)	500 FPM (2.5 m/s)
Resistance	1.0 "W.G. (249 PA)	1.4 "W.G. (348 PA)
Temperature limit	500 °F (260 °C)	500 °F (260 °C)
Frame construction	Stainless steel	Stainless steel
Sealant	Silicone compound	Silicone compound
Standard efficiencies	99.97% and 99.99%	99.97% and 99.99%

LOCAL REPRESENTATIVE

Tri-Dim Filter Corporation is committed to continual product development - all descriptions, specifications and performance data are subject to change without notice. Tri-Dim products are manufactured to exacting criteria - there can be a ±5% variance in filter performance.